

ADMINISTRATIVE APPROVAL
LEE COUNTY, FLORIDA

WHEREAS, Bonita Beach Partners LLC, represented by Nelson Marine Construction Inc. filed an application for administrative approval for dock setback variance for development of property located at 26323 Hickory Blvd., described more particularly as:

LEGAL DESCRIPTION; In Section 25, Township 47 South, Range 24 East, Lee County, Florida:

LOT 1, VILLA POSITANO SUBDIVISION, AS RECORDED IN PLAT BOOK 75, PAGE 46, PUBLIC RECORDS OF LEE COUNTY, FLORIDA.

WHEREAS, the applicant has indicated the property's current STRAP number is 25-47-24-B2-04400.0010; and

WHEREAS, an application for approval of an administrative dock variance has been filed pursuant to the Lee County Land Development Code, Section 26-71(d)(4); and

WHEREAS, the Lee County Land Development Code provides for administrative approval from the Dock and Shoreline Structure Regulations for matters involving dock side setbacks in LDC Section 26-71; and

WHEREAS, administrative approval is requested in the RPD zoning district as provided by the Lee County Land Development Code, Chapter 26, from the Lee County Dock and Shoreline Regulations contained in LDC, Section 26-71, from the minimum required 25 feet to 20 feet; and

WHEREAS, the subject application and plans have been reviewed by the Lee County Department of Community Development in accordance with applicable regulations for compliance with all terms of the administrative approval; and

WHEREAS, the following findings of fact are offered:

1. The subject property is waterfront that measures approximately 50 feet wide at the platted mean high water line.
2. The property is narrow; therefore the placement of the proposed docking facility cannot meet the side setbacks required for docks in natural waterbodies.
3. The proposed dock is for single-family residential use and had been limited to a 4 feet wide walkway with two boatlifts.

NOW, THEREFORE, IT IS HEREBY DETERMINED that the application for Administrative Approval for relief from the Lee County Land Development Code Section 26-71 (d)(2) from the requirement that all private single-family docking facilities in natural water bodies must be setback 25 feet from all adjoining side lot and side riparian lines to allow a 20 foot setback is **APPROVED**.

Approval is subject to the following conditions:

- 1. The approval is limited to a single dock as depicted in the construction drawing prepared by Nelson Marine Construction, Inc. dated stamped received August 5, 2005.**

DULY PASSED AND ADOPTED this 15th day of September, A.D., 2005.

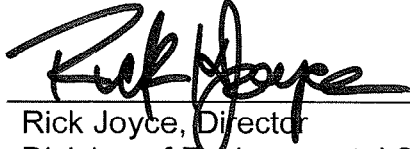
BY: 
Rick Joyce, Director
Division of Environmental Sciences
Department of Community Development

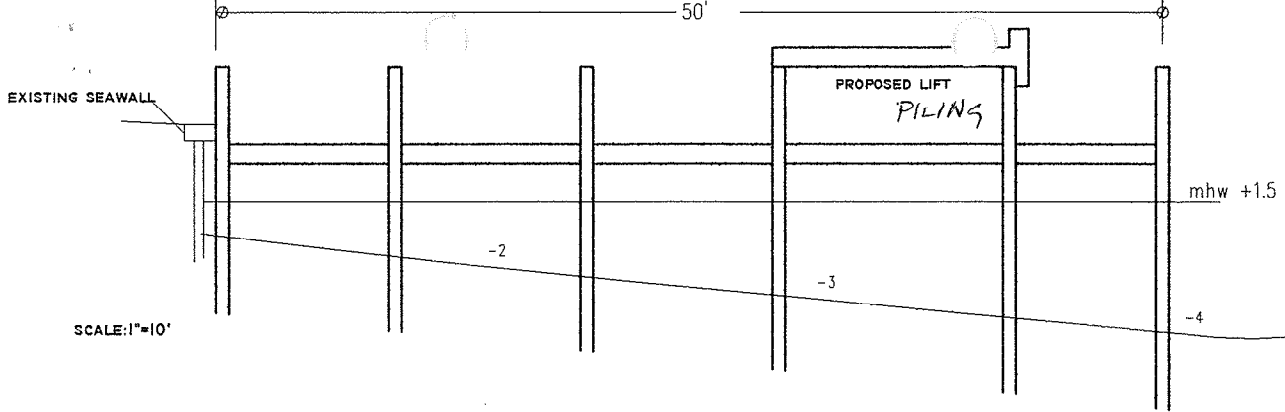

ESTERO BAY (HOGUE CHANNEL ± 250' WIDE)

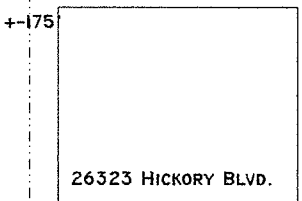
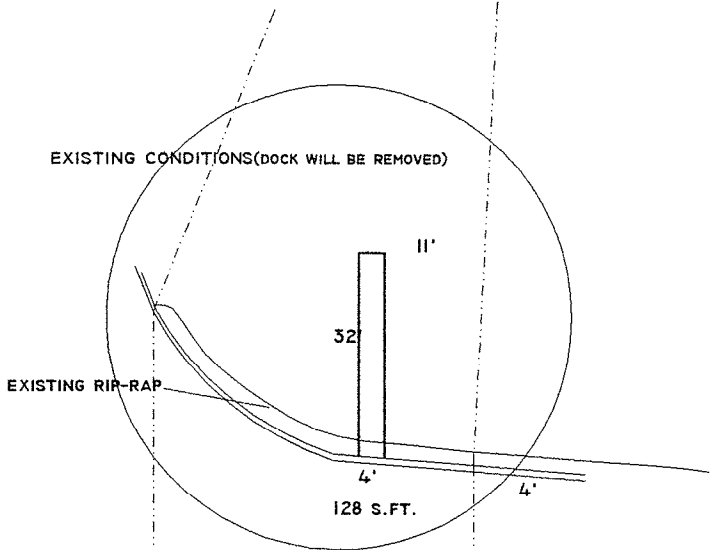
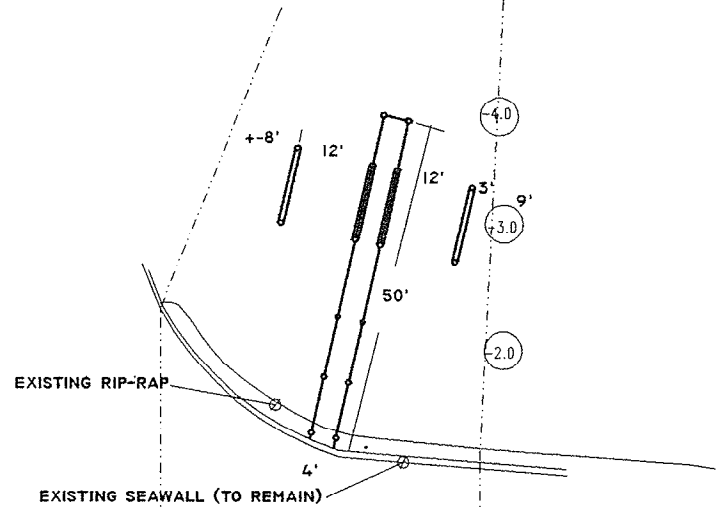

APPROVED
Plan

Subject to Case # ADD2005-00165
Date 9/15/05

ADD 2005-00165

OWNER : BONITA BEACH PARTNERS
PURPOSE : REPLACE EXISTING DOCK

NELSON
MARINE CONSTRUCTION

RECEIVED
AUG 05 2005

IN BONITA SPRINGS
COUNTY : LEE
*BONITABEACHPARTNERSDOCK23